

Born For  
Rental. Sale. Own

# MOBILE POWER SOLUTION

Designed To Meet Variety Of Needs  
Mobile Power Solution Featured With

- Mobile Solar LED Lighting
- Mobile Solar Surveillance
- Mobile Solar Generator
- Mobile Solar Telecom

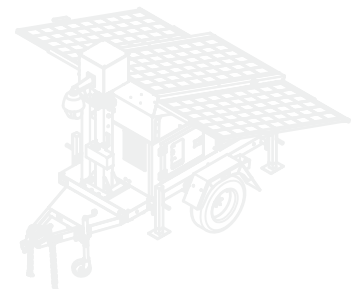

# WHY CHOOSE BIGLUX

## 5S reasons

- 1S** | Smart, Safe and Stable Design
- 2S** | Selective High Quality Material
- 3S** | Strong Lean Manufacturing
- 4S** | Strict Quality Control
- 5S** | Supportive Sales and Service Team



## INNOVATION DRIVEN QUALITY ORIENTED

By utilizing abundant available resources namely raw materials, new technology, work force and sub assembly resources from China, BIGLUX is able to provide highly **COMPETITIVE** pricing compared with products of same class and technology.

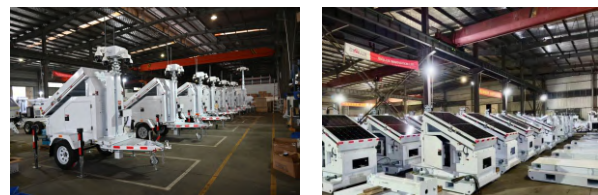

### **10+** YEARS

We have been working in the industry for many years.

### **20+** CERTIFICATES

We have obtained most of the professional certificates in the industry and insist on international standards of production.

### **100+** REPEAT CUSTOMERS

We have a lot of repeat customers every year.

# WHY CHOOSE SOLAR TOWER

## Choice of Times

With the development of solar technology, 435W 22.3% Solar Panel enough to supply power to high light LED and Smart Camera, 4000 Cycle Lithium Battery ensure the electric system working 10 years at least. That's why Solar Tower which combine the Solar & LFP Battery won the favor of the market & project.



## Working Anywhere

Different with the Street Light/CCTV Pole, Solar Tower have advantage of Self-powered and Mobility, that's means you could deploy the trailer in any where, start work without grid connect, no need people watching, no need worry the rough roads and temporary working site.

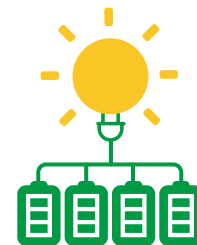

## Save More Money

Compare with Diesel Genset Tower, Solar Tower is not just quiet, but could save more money; no fuel save USD4200; no need refuel, free maintain, less repair save USD8800; faster ROI. 90~180 Days return your invest.

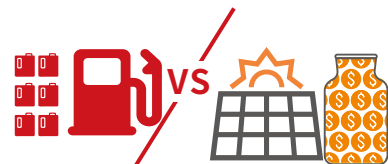

## Green Future

Each kWh Solar Power from Solar Tower could save 0.997kg CO<sup>2</sup>emission. Each UST-900 could generate 13140kWh in 10 years life, and save 13100kg CO<sup>2</sup>emission, same about planting 14 trees. Let's make the future green together.



## Multiple Functions and Applications

BIGLUX mobile solar-powered tower is convenient and environmentally friendly. It can provide round-the-clock monitoring, equivalent to the effect of 3 security guards. It can be placed anywhere you want. It can also work as mobile lighting tower. By adopting the latest solar panels, digital camera technology, and smart controlling systems, we can supply the best energy-saving solar CCTV tower, lighting tower and telecom tower for parking lots, construction sites, mining, sports, events, and emergency applications.



# APPLICATIONS

Solar light towers are used in construction sites, outdoor events, remote areas, and industrial facilities to provide lighting. They are ideal for places without access to traditional power sources or as temporary lighting solutions.

Solar surveillance trailers are employed in construction sites, parking lots, and remote areas for security monitoring. Their portability and independence from the grid make them versatile and useful in various settings.



# OPTIONAL



## LFP Battery

LFP battery have 6 times longer use life than GEL battery smaller body and lighter weight,it's worthful choice.



## Victron

Powerful remote system,monitoring the Solar & Battery situation and remote control LED Light on App.



## AL-KO

Stronger and durable axle,no worry about the muddy & rugged road,it's popular choice in AU & EU.

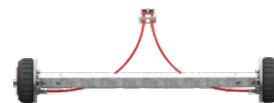

## Skid Type

Change the trailer to skid base,more stable,no need apply trailer licence.



## Inverter

Supply the AC Power to site tools,electric appliance also mobile phone and Laptop.



## Wind Turbine

400W Vertical Wind Turbine could as a backup power if there have big wind.It's popular choice in MiddleEast.



## Backup Genset

3kW Gasoline & 5kW Diesel genset will supply extra 10+ days backup time in badly no sun weather.



## Fuel Cell

Supply 125W green,clean and continuously power to CCTV system even if the extremely harsh enviroment.



# HiSOLO

## Solar Surveillance Trailer Tower



### SPECIFICATION

BL2P-G7MHS	
Solar Panel	2 × 450W
Panel Lifting	30°/40°/50°/60°, Electric Lifting
GEL Battery	4 × 200Ah DC12V
Battery Capacity	9600Wh 80% DoC
System Voltage	DC24V
Battery Charger	Yes
CCTV	2 × 4MP PTZ + 2 × 4MP Bullet
Storage	8TB NVR, 48 Days
4G Router	Yes
Loud Speaker	Yes
Controller	40A MPPT
Mast & Height	6 Sections 7M
Mast Lifting	Manual Winch
Trailer Standard	US / AU / EU
Hitch	2" Ball / 3" Ring
Brake	Electric
Axle	Single
Tire	14 inch
Outriggers	4 ×
Lifting Ring	4 ×
Forklift Holes	6 ×
Working Temp	-35°C~60°C
Charging Time	9.3 hours
Running Time	5.3 Days
Dimension(mm)	2350*1650*2200
Weight	1100kgs
QTY in 20' / 40'	6units / 14 units

### OPTIONAL

LFP Battery

Victron

AL-KO

Skid Type

Fuel Cell

### CCTV System

4MP PTZ × 2

4MP Bullet × 2

8TB NVR

4G Router

Loud Speaker

### CONTAINER LOADING

20' | 6 units

40' | 14 units



# HiSECURITY

## Solar Surveillance Trailer Tower



### SPECIFICATION

BL3P-G9EHS	
Solar Panel	3 × 435W
Panel Lifting	30°~45°, Electric Lifting
GEL Battery	6 × 200Ah DC12V
Battery Capacity	14400Wh 80% DoC
System Voltage	DC24V
Battery Charger	Yes
LED Lamp	4 × 4MP PTZ
Lighting Area (5 Lux)	4TB NVR, 48 Days
Rotation	Yes
Tilt	Yes
Controller	60A MPPT
Mast & Height	5 Sections 9M
Mast Lifting	Electric Winch
Trailer Standard	US / AU / EU
Hitch	2" Ball / 3" Ring
Brake	Mechanical
Axle	Single
Tire	15 inch
Outriggers	4 ×
Lifting Ring	4 ×
Forklift Holes	2 ×
Working Temp	-35°C~60°C
Charging Time	9.3 hours
Running Time	8 Days
Dimension(mm)	3550*1650*2800
Weight	1400kg
QTY in 20' / 40'	3 units / 7 units

### OPTIONAL

LFP Battery	Victron	AL-KO	Skid Type
Fuel Cell	Backup Genset		

### CCTV System

4MP PTZ × 4	8TB NVR	4G Router
Loud Speaker		

### CONTAINER LOADING

20' | 3 units      40' | 7 units

# HiSECURITY

## Solar Surveillance Trailer Tower



### SPECIFICATION

BL2P-G7MHS	
Solar Panel	2 × 435W
Panel Lifting	10°~45° Manual Lifting
GEL Battery	4 × 200Ah DC12V
Battery Capacity	9600Wh 80% DoC
System Voltage	DC24V
Battery Charger	Yes
CCTV	2 × 4MP PTZ + 2 × 4MP Bullet
Storage	4TB NVR, 48 Days
4G Router	Yes
Loud Speaker	Yes
Controller	40A MPPT
Mast & Height	5 Sections 7M
Mast Lifting	Manual Winch
Trailer Standard	US / AU / EU
Hitch	2" Ball / 3" Ring
Brake	Electric
Axle	Single
Tire	14 inch
Outriggers	4 ×
Lifting Ring	4 ×
Forklift Holes	2 ×
Working Temp	-35°C~60°C
Charging Time	9.3 hours
Running Time	5.3 Days
Dimension(mm)	3700*2150*2750
Weight	1000kgs
QTY in 20' / 40'	6 units / 14 units

### OPTIONAL

LFP Battery

Victron

AL-KO

Skid Type

### CCTV System

4MP PTZ × 2

4MP Bullet × 2

8TB NVR

4G Router

Loud Speaker

### CONTAINER LOADING

20' | 6 units    40' | 14 units



The above parameters are for reference only. All products are subject to the actual products received.



# HiSECURITY

## Solar Surveillance Trailer Tower



### SPECIFICATION

BL4P-G9EHS	
Solar Panel	4 × 460W
Panel Lifting	30°~45°, Electric Lifting
GEL Battery	8 × 200Ah DC12V
Battery Capacity	19200Wh 80% DoC
System Voltage	DC48V
Battery Charger	Yes
CCTV	4 × 4MP PTZ
Storage	4TB NVR, 48 Days
4G Router	Yes
Loud Speaker	Yes
Controller	40A MPPT
Mast & Height	5 Sections 9M
Mast Lifting	Electric Winch
Trailer Standard	US / AU / EU
Hitch	2" Ball / 3" Ring
Brake	Mechanical
Axle	Single
Tire	15 inch
Outriggers	4 ×
Lifting Ring	4 ×
Forklift Holes	2 ×
Working Temp	-35°C~60°C
Charging Time	9.3 hours
Running Time	10.7 Days
Dimension(mm)	3950*1750*2800
Weight	1600kgs
QTY in 20' / 40'	2 units / 5units

### OPTIONAL

LFP Battery

Victron

AL-KO

Skid Type

### CCTV System

4MP PTZ × 4

8TB NVR

4G Router

Loud Speaker

### CONTAINER LOADING

20' | 2units      40' | 5 units



# HiSECURITY

## Solar Surveillance Trailer Tower



### SPECIFICATION

BL1P-G7MHS	
Solar Panel	1 × 435W
Panel Lifting	10°~45° Manual Lifting
GEL Battery	2 × 200Ah DC12V
Battery Capacity	4800Wh 80% DoC
System Voltage	DC24V
Battery Charger	Yes
CCTV	1 × 4MP PTZ + 2 × 4MP Bullet
Storage	3 × 512GB, 21 Days
4G Router	Yes
Loud Speaker	Yes
Controller	40A MPPT
Mast & Height	5 Sections 7M
Mast Lifting	Manual Winch
Trailer Standard	US / AU / EU
Hitch	2" Ball / 3" Ring
Brake	Electric
Axle	Single
Tire	14 inch
Outriggers	4 ×
Lifting Ring	4 ×
Forklift Holes	2 ×
Working Temp	-35°C~60°C
Charging Time	9.3 hours
Running Time	4 Days
Dimension(mm)	2500*2150*2700
Weight	900kgs
QTY in 20' / 40'	7 units / 16 units

### OPTIONAL

LFP Battery

Victron

AL-KO

Skid Type

### CCTV System

4MP PTZ × 1

4MP Bullet × 2

4G Router

Loud Speaker

### CONTAINER LOADING

20' | 7units      40' | 16 units



# HiGUARD

## Solar camera Tower



### SPECIFICATION



BL1P-L4MHS	
Solar Panel	1 × 435W
Panel Lifting	0°~90° Manual Lifting
LFP Battery	1 × 200Ah DC12.8V
Battery Capacity	2560Wh 95% DoC
System Voltage	DC12V
Battery Charger	Optional
CCTV	1 × 4MP PTZ + 2 × 4MP Turret
Storage	3 × 512GB, 21 Days
4G Router	Yes
Loud Speaker	Integrated in PTZ
Controller	40A MPPT
Mast & Height	4 Sections 4M
Mast Lifting	Manual Winch
Trailer Standard	/
Hitch	/
Brake	/
Axle	/
Tire	/
Outriggers	Optional
Lifting Ring	4 ×
Forklift Holes	4 ×
Working Temp	-20°C~50°C
Charging Time	5.9 hours
Running Time	5 Days
Dimension(mm)	1000*1000*2900
Weight	400kgs
QTY in 20' / 40'	10 units / 20 units

### OPTIONAL



Victron

### CCTV System

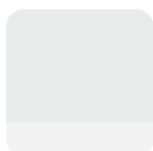
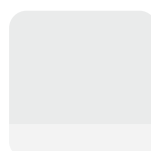
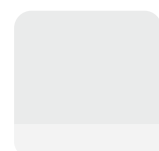
 4MP PTZ×1	 4MP Turret×2	 4G Router
		

### CONTAINER LOADING

20' | 10 units    40' | 20 units



# HiPT

## Solar Camera Tower



## SPECIFICATION

BLPT-05MHS	
Solar Panel	1 × 40W
Panel Lifting	0°~90° Manual Lifting
LFP Battery	2 × 8.3Ah DC12.6V
Battery Capacity	206Wh 95% DoC
System Voltage	DC12V
Battery Charger	/
CCTV	1 × 4MP PTZ
Storage	1 × 512GB, 21 Days
4G Router	Integrated in PTZ
Loud Speaker	Integrated in PTZ
Controller	MPPT
Mast & Height	3 Sections 5M
Mast Lifting	Manual Winch
Trailer Standard	/
Hitch	/
Brake	/
Axle	/
Tire	/
Outriggers	/
Lifting Ring	4 ×
Forklift Holes	4 ×
Working Temp	-20°C~50°C
Charging Time	6.9 hours
Running Time	1.4 Days
Dimension(mm)	1000*1000*2500
Weight	200kgs
QTY in 20' / 40'	10 units / 20 units

### CCTV System

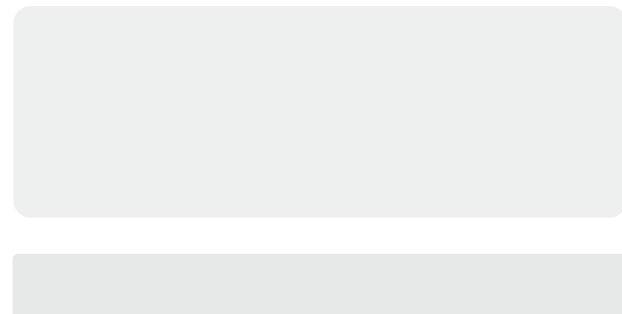
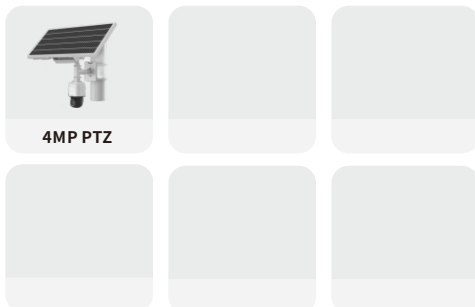

## CONTAINER LOADING

20' | 10 units    40' | 20 units



# HiTAPER

## Solar Camera Tower



### SPECIFICATION

BLTA-GTEHS	
Solar Panel	/
Panel Lifting	/
GEL Battery	2 × 150Ah DC12V
Battery Capacity	3600Wh 80% DoC
System Voltage	DC24V
Battery Charger	Yes
CCTV	2 × 4MP PTZ + 2 × 4MP Bullet
Storage	4TB NVR,48 Days
4G Router	Yes
Loud Speaker	Yes
Controller	/
Mast & Height	5 Sections 7M
Mast Lifting	Electric Winch
Trailer Standard	/
Hitch	/
Brake	/
Axle	/
Tire	/
Outriggers	4 ×
Lifting Ring	4 ×
Forklift Holes	4 ×
Working Temp	-35°C~60°C
Charging Time	2.7 hours by AC
Running Time	2 Days
Dimension(mm)	1000*1000*2500
Weight	350kgs
QTY in 20' / 40'	10 units / 20 units

### CCTV System

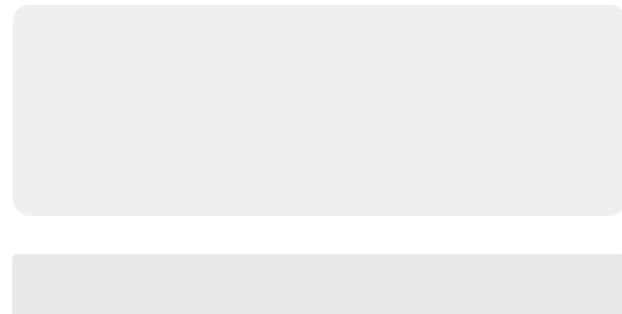
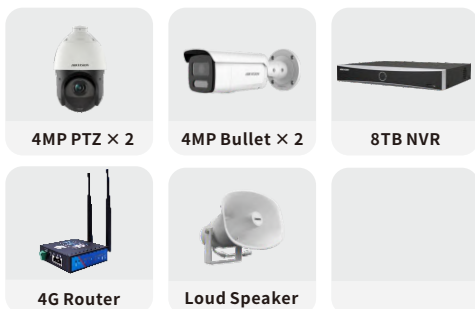

### CONTAINER LOADING

20' | 10 units    40' | 20 units



# HiLIGHT

Mobile Solar Light Tower

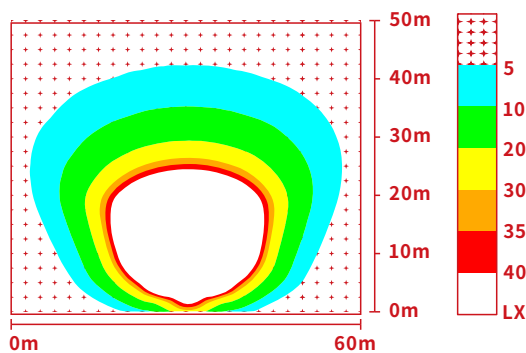

## SPECIFICATION

BLEP-G9EHL600	
Solar Panel	3 × 435W
Panel Lifting	30°~45°, Electric Lifting
GEL Battery	6 × 200Ah DC12V
Battery Capacity	14400Wh 80% DoC
System Voltage	DC24V
Battery Charger	Yes
LED Lamp	4 × 150W, 90000Lms
Lighting Area (5 Lux)	2310m <sup>2</sup>
Rotation	350° Electric
Tilt	90° Electric
Controller	60A MPPT
Mast & Height	5 Sections 9M
Mast Lifting	Electric Winch
Trailer Standard	US / AU / EU
Hitch	2" Ball / 3" Ring
Brake	Mechanical
Axle	Single
Tire	15 inch
Outriggers	4 ×
Lifting Ring	4 ×
Forklift Holes	2 ×
Working Temp	-35°C~60°C
Charging Time	9.3 hours
Running Time	19.2 hours
Dimension(mm)	3550*1650*2800
Weight	1400kgs
QTY in 20' / 40'	3 units / 7 units

## OPTIONAL

LFP Battery	Backup Genset	Wind Turbine	Inverter
Victron	AL-KO	Skid Type	

## CONTAINER LOADING

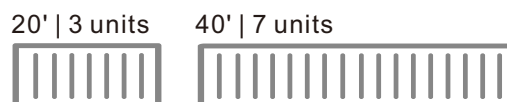

# HiLIGHT

Mobile Solar Light Tower

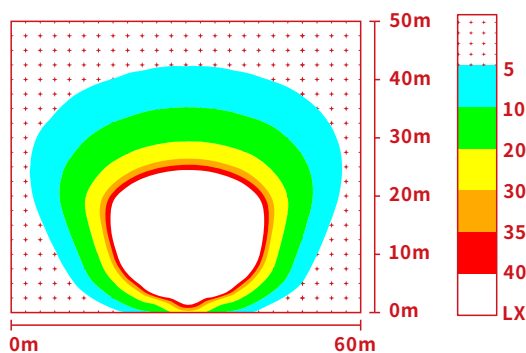

## SPECIFICATION

BL4P-G9EHL800	
Solar Panel	4 × 460W
Panel Lifting	30°~45°, Electric Lifting
GEL Battery	8 × 200Ah DC12V
Battery Capacity	19200Wh 80% DoC
System Voltage	DC48V
Battery Charger	Yes
LED Lamp	4 × 200W, 120000Lms
Lighting Area (5 Lux)	2734m <sup>2</sup>
Rotation	350° Electric
Tilt	90° Electric
Controller	40A MPPT
Mast & Height	5 Sections 9M
Mast Lifting	Electric Winch
Trailer Standard	US / AU / EU
Hitch	2" Ball / 3" Ring
Brake	Mechanical
Axle	Single
Tire	15 inch
Outriggers	4 ×
Lifting Ring	4 ×
Forklift Holes	2 ×
Working Temp	-35°C~60°C
Charging Time	8.8 hours
Running Time	19.2 hours
Dimension(mm)	3650*2250*2800
Weight	1600kgs
QTY in 20' / 40'	2 units / 5 units

## OPTIONAL

LFP Battery	Backup Genset	Wind Turbine	Inverter
Victron	AL-KO	Skid Type	

## CONTAINER LOADING

20' | 2 units



40' | 5 units



# HiLIGHT

Mobile Solar Light Tower

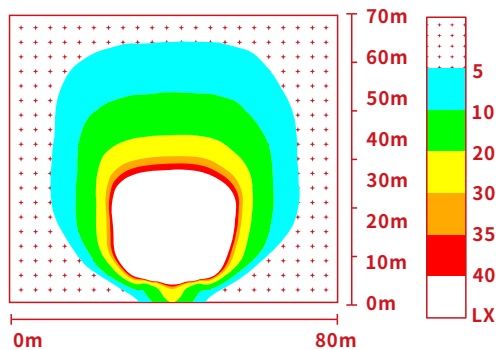

## SPECIFICATION

BL6P-G9HHL1200	
Solar Panel	6 × 460W
Panel Lifting	0°~25° Hydraulic Lifting
GEL Battery	12 × 200Ah DC12V,Auto-Fan
Battery Capacity	28800Wh 80% DoC
System Voltage	DC48V
Battery Charger	Yes
LED Lamp	4 × 300W,180000Lms
Lighting Area (5 Lux)	3184m <sup>2</sup>
Rotation	350° Electric
Tilt	90° Electric
Controller	60A MPPT
Mast & Height	9 Sections 9M
Mast Lifting	Hydraulic
Trailer Standard	US / AU / EU
Hitch	2" Ball / 3" Ring
Brake	Electric
Axle	Double
Tire	15 inch
Outriggers	4 ×
Lifting Ring	4 ×
Forklift Holes	2 ×
Working Temp	-35°C~60°C
Charging Time	8.8 hours
Running Time	19.2 hours
Dimension(mm)	4150*2250*2800
Weight	2400kgs
QTY in 20' / 40'	2 units / 4 units

## OPTIONAL

LFP Battery	Backup Genset	Wind Turbine	Inverter
Victron	AL-KO	Skid Type	

## CONTAINER LOADING



The above parameters are for reference only. All products are subject to the actual products received.



# HiLIGHT

Mobile Solar Light Tower

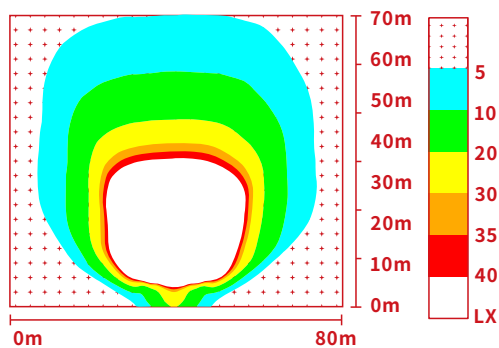

## SPECIFICATION

BL8P-G9HHL1600	
Solar Panel	8 × 460W
Panel Lifting	0°~25° Hydraulic Lifting
GEL Battery	16 × 200Ah DC12V,Auto-Fan
Battery Capacity	38400Wh 80% DoC
System Voltage	DC48V
Battery Charger	Yes
LED Lamp	4 × 400W,240000Lms
Lighting Area (5 Lux)	3887m <sup>2</sup>
Rotation	350° Electric
Tilt	90° Electric
Controller	80A MPPT
Mast & Height	9 Sections 9M
Mast Lifting	Hydraulic
Trailer Standard	US / AU / EU
Hitch	2" Ball / 3" Ring
Brake	Electric
Axle	Double
Tire	15 inch
Outriggers	4 ×
Lifting Ring	4 ×
Forklift Holes	2 ×
Working Temp	-35°C~60°C
Charging Time	8.8 hours
Running Time	19.2 hours
Dimension(mm)	4150*2250*2800
Weight	2800kgs
QTY in 20' / 40'	2 units / 4 units

## OPTIONAL

LFP Battery	Backup Genset	Wind Turbine	Inverter
Victron	AL-KO	Skid Type	

## CONTAINER LOADING

20' | 2 units



40' | 4 units



# HiLIGHT

Mobile Solar Light Tower

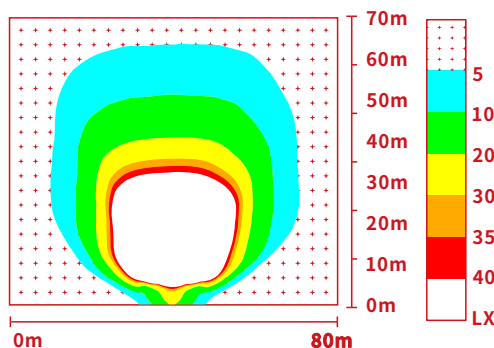

## SPECIFICATION

BL6P-G9HHL1200	
Solar Panel	6 × 435W
Panel Lifting	0°~120° Hydraulic Lifting
LFP Battery	6 × 100Ah DC48V, Auto-Fan
Battery Capacity	19200Wh 80% DoC
System Voltage	DC48V
Battery Charger	Yes
LED Lamp	4 × 300W, 180000Lms
Lighting Area (5 Lux)	3184m <sup>2</sup>
Rotation	350° Electric
Tilt	90° Electric
Controller	60A MPPT
Mast & Height	9 Sections 9M
Mast Lifting	Hydraulic
Trailer Standard	/
Hitch	/
Brake	/
Axle	/
Tire	/
Outriggers	4 ×
Lifting Ring	4 ×
Forklift Holes	2 ×
Working Temp	-20°C~50°C
Charging Time	11 hours
Running Time	22.8 hours
Dimension(mm)	3675*4850*2800
Weight	1375kgs
QTY in 20' / 40'	5 units / 10 units

## OPTIONAL

Victron

Inverter

Wind Turbine

## CONTAINER LOADING

20' | 5 units

40' | 10 units

The above parameters are for reference only. All products are subject to the actual products received.

# HiLIGHT

Mobile Solar Light Tower

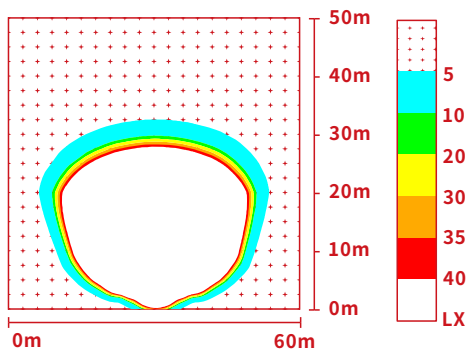

## SPECIFICATION

BL1P-G7MHL1200	
Solar Panel	1 × 435W
Panel Lifting	10°~45° Manual Lifting
GEL Battery	2 × 200Ah DC12V
Battery Capacity	4800Wh 80% DoC
System Voltage	DC24V
Battery Charger	Yes
LED Lamp	2 × 100W,30000Lms
Lighting Area (5 Lux)	1013m <sup>2</sup>
Rotation	350° Electric
Tilt	90° Electric
Controller	40A MPPT
Mast & Height	5 Sections 7M
Mast Lifting	Manual Winch
Trailer Standard	US / AU / EU
Hitch	2" Ball / 3" Ring
Brake	Electric
Axle	Single
Tire	14 inch
Outriggers	4 ×
Lifting Ring	4 ×
Forklift Holes	2 ×
Working Temp	-35°C~60°C
Charging Time	9.3 hours
Running Time	19.2 hours
Dimension(mm)	2500*2150*2700
Weight	900kgs
QTY in 20' / 40'	7 units / 16 units

## OPTIONAL

LFP Battery

Victron

AL-KO

Skid Type

## CONTAINER LOADING

20' | 7 units



40' | 16 units



# HiLIGHT

Mobile Solar Light Tower



## SPECIFICATION

BL2P-G7MHL400	
Solar Panel	2 × 435W
Panel Lifting	10°~45° Manual Lifting
GEL Battery	4 × 200Ah DC12V
Battery Capacity	9600Wh 80% DoC
System Voltage	DC24V
Battery Charger	Yes
LED Lamp	4 × 100W,60000Lms
Lighting Area (5 Lux)	1481m <sup>2</sup>
Rotation	350° Electric
Tilt	90° Electric
Controller	40A MPPT
Mast & Height	5 Sections 7M
Mast Lifting	Manual Winch
Trailer Standard	US / AU / EU
Hitch	2" Ball / 3" Ring
Brake	Electric
Axle	Single
Tire	14 inch
Outriggers	4 ×
Lifting Ring	4 ×
Forklift Holes	2 ×
Working Temp	-35°C~60°C
Charging Time	9.3 hours
Running Time	19.2 hours
Dimension(mm)	3700*2150*2750
Weight	1000kgs
QTY in 20' / 40'	6 units / 14 units

## OPTIONAL

LFP Battery

Victron

AL-KO

Skid Type

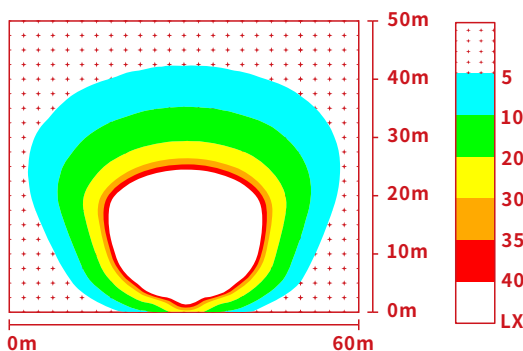

## CONTAINER LOADING

20' | 6 units



40' | 14 units



The above parameters are for reference only. All products are subject to the actual products received.

# HiGUARD

## Mobile Light Tower



### SPECIFICATION

BL1P-L4MHL200	
Solar Panel	1 × 435W
Panel Lifting	0°~90° Manual Lifting
LFP Battery	1 × 200Ah DC12.8V
Battery Capacity	2560Wh 95% DoC
System Voltage	DC12V
Battery Charger	Optional
LED Lamp	2 × 100W,30000Lms
Lighting Area (5 Lux)	1013m <sup>2</sup>
Rotation	/
Tilt	/
Controller	40A MPPT
Mast & Height	4 Sections 4M
Mast Lifting	Manual Winch
Trailer Standard	/
Hitch	/
Brake	/
Axle	/
Tire	/
Outriggers	Optional
Lifting Ring	4 ×
Forklift Holes	4 ×
Working Temp	-20°C~50°C
Charging Time	5.9 hours
Running Time	12.2 hours
Dimension(mm)	1000*1000*2900
Weight	400kgs
QTY in 20' / 40'	10 units / 20 units

### OPTIONAL

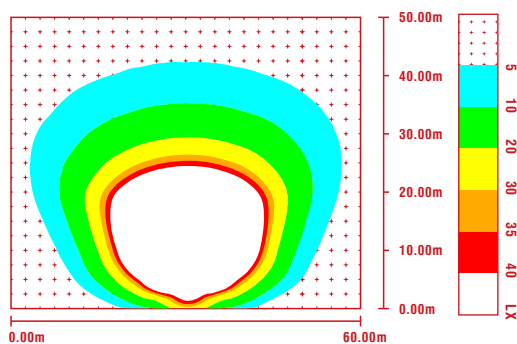
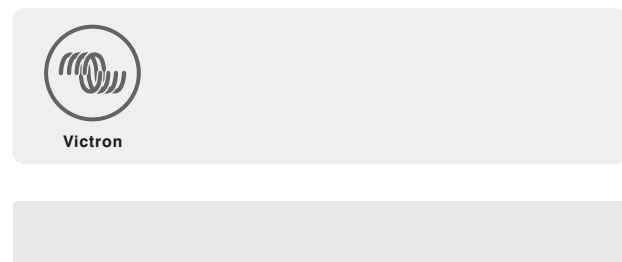

### CONTAINER LOADING

20' | 10 units



40' | 20 units



The above parameters are for reference only. All products are subject to the actual products received.

# HiTAPER

## Mobile Light Tower



### SPECIFICATION

BLTA-G7EHL400	
Solar Panel	/
Panel Lifting	/
GEL Battery	2 × 150Ah DC12V
Battery Capacity	3600Wh 80% DoC
System Voltage	DC24V
Battery Charger	Yes
LED Lamp	4 × 100W,60000Lms
Lighting Area (5 Lux)	1481m <sup>2</sup>
Rotation	350° Electric
Tilt	90° Electric
Controller	/
Mast & Height	5 Sections 7M
Mast Lifting	Electric Winch
Trailer Standard	/
Hitch	/
Brake	/
Axle	/
Tire	/
Outriggers	4 ×
Lifting Ring	4 ×
Forklift Holes	4 ×
Working Temp	-35°C~60°C
Charging Time	2.7 hours by AC
Running Time	7.2 hours
Dimension(mm)	1000*1000*2500
Weight	350kgs
QTY in 20' / 40'	10 units / 20 units

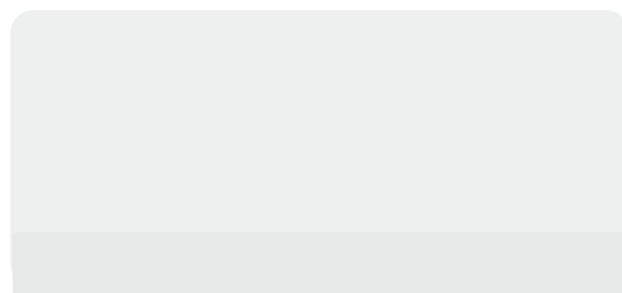
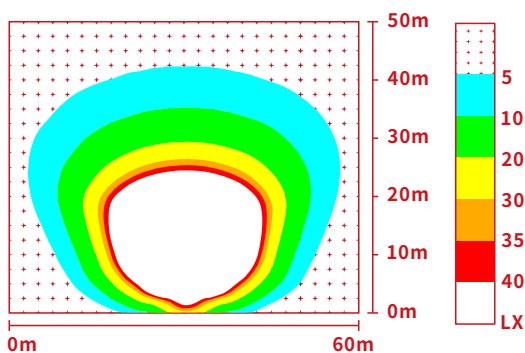

### CONTAINER LOADING

20' | 10 units



40' | 20 units



# HiPT

## Mobile Light Tower



## SPECIFICATION

BLPT-L5MHL30	
Solar Panel	1 × 40W
Panel Lifting	0°~90° Manual Lifting
LFP Battery	1 × 18Ah DC12.8V
Battery Capacity	230Wh 95% DoC
System Voltage	DC12V
Battery Charger	/
LED Lamp	1 × 30W,6000Lms
Lighting Area (5 Lux)	237
Rotation	/
Tilt	/
Controller	PWM
Mast & Height	3 Sections 5M
Mast Lifting	Manual Winch
Trailer Standard	/
Hitch	/
Brake	/
Axle	/
Tire	/
Outriggers	/
Lifting Ring	4 ×
Forklift Holes	4 ×
Working Temp	-20°C~50°C
Charging Time	6 hours
Running Time	7.7 hours
Dimension(mm)	1000*1000*2500
Weight	200kgs
QTY in 20' / 40'	10 units / 20 units

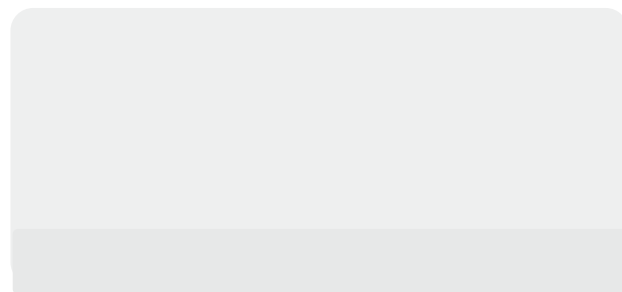
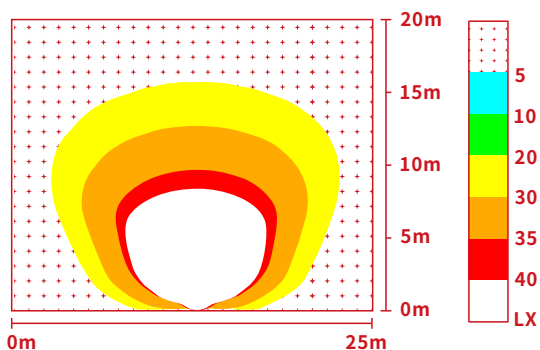

## CONTAINER LOADING

20' | 10 units



40' | 20 units



# CUBE-X/CUBE-X HYBRID

## Diesel Light Tower



MODEL	CUBE-X	CUBE-X HYBRID
<b>Unit</b>		
Genset rated Power (KW)	6	6
Dimension	1180×1180×2684mm	1380×1180×2784mm
Height extended fully	9m	9m
Gross Weight	1100kgs	1200kgs
<b>Engine</b>		
Engine Model	Perkins 403D-11G	Perkins 403D-11G
Rated Speed (rpm)	1500/1800	1500/1800
Cylinder No.	3	3
Engine type	4 stroke,water-cooled	4 stroke,water-cooled
Air intake method	Naturally aspirated	Naturally aspirated
Emission	Tier3	Tier3
<b>Alternator</b>		
Model	MeccAlte LT3N-130/4	MeccAlte LT3N-130/4
Frequency (HZ)	50/60	50/60
Rated voltage	230V (50HZ), 240(60HZ) AC	230V (50HZ), 240(60HZ) AC
Insulation class	Class H	Class H
Protection grade	IP23	IP23
<b>Battery</b>		
Battery Type	/	LFP
Battery Capacity	/	200AH 25.6V
	/	5KW.H
<b>Mast and Light</b>		
Light type	LED	LED
Luminous Flux	210000 LM	210000 LM
Light Qty x WATT	4×500W	4×500W
Mast Sections	9	9
Mast lifting method	Hydraulic	Hydraulic
Light Rotation	Electric motor 355 degrees	Electric motor 355 degrees
Light Angle Adjust	Electric actuator	Electric actuator
<b>Other Item</b>		
Fuel Tank Type	Metal	Metal
Fuel Tank capacity	100L	100L
Operating hours	80 Hrs	120 Hrs
<b>Controller</b>		
	Smartgen ALC708	Smartgen ALC708
Output	2 receptacles	2 receptacles
Max.Against Wind	20 m/s	20 m/s
Noise level dBA@7M	63dB(A) at 7m	63dB(A) at 7m
Max.Loading Qty by 40HQ	20	20

The above parameters are for reference only. All products are subject to the actual products received.



# HiDIESEL

## Diesel Light Tower



MODEL	BLGT-7000PLED
<b>Unit</b>	
Genset rated Power (KW)	7
Dimension	3000×1538×2800mm
Height extended fully	9m (12m optional)
Gross Weight	1350kgs
<b>Engine</b>	
Engine Model	Perkins 403D-11G
Rated Speed (rpm)	1500/1800
Cylinder No.	3
Engine type	4 stroke,water-cooled
Air intake method	Naturally aspirated
Emission	Tier3
<b>Alternator</b>	
Model	MeccAlte LT3N-160/4
Frequency (HZ)	50/60
Rated voltage	230V (50HZ), 240(60HZ) AC
Insulation class	Class H
Protection grade	IP23
<b>Mast and Light</b>	
Light type	LED
Luminous Flux	210000 LM
Light Qty x WATT	4×500W
Mast Sections	9
Mast lifting method	Hydraulic
Light Rotation	No/355 degrees optional
Light Angle Adjust	Electric actuator
<b>Trailer</b>	
Suspension	Leaf spring with mechanical braker
Towing Bar	Foldable Tow bar with Jockey wheel
Stabilizing Leg	4Pcs Manual Stabilizing Leg
Rim & Tyre	14"
Towing coupler	50mm ball / 70mm Ring
Tail Lights	complex tail light
Max Towing speed	80km/h
<b>Other Item</b>	
Fuel Tank Type	Metal
Fuel Tank capacity	100L
Operating hours	80 Hrs
Controller	Smartgen ALC708
Output	2 receptacles
Max.Against Wind	20 m/s
Noise level dBA@7M	63dB(A) at 7m
Max.Loading Qty by 40HQ	7

The above parameters are for reference only. All products are subject to the actual products received.

# HiDIESEL

## Diesel Light Tower



MODEL	BLGT-4000PMH	BLGT-4000PLED
<b>Unit</b>		
Genset rated Power (KW)	6	6
Dimension	3031×1488×3327mm	3031×1488×3220mm
Height extended fully	7.5m (9m optional)	7.5m (9m optional)
Gross Weight	1300kg	1300kgs
<b>Engine</b>		
Engine Model	Perkins 403D-11G	Perkins 403D-11G
Rated Speed (rpm)	1500/1800	1500/1800
Cylinder No.	3	3
Engine type	4 stroke,water-cooled	4 stroke,water-cooled
Air intake method	Naturally aspirated	Naturally aspirated
Emission	Tier3	Tier3
<b>Alternator</b>		
Model	MeccAlte LT3N-130/4	MeccAlte LT3N-130/4
Frequency (HZ)	50/60	50/60
Rated voltage	230V (50HZ), 240(60HZ) AC	230V (50HZ), 240(60HZ) AC
Insulation class	Class H	Class H
Protection grade	IP23	IP23
<b>Mast and Light</b>		
Light type	Metal Halide	LED
Luminous Flux	360000 LM	210000 LM
Light Qty x WATT	4×1000W	4×350W
Mast Sections	5	5
Mast lifting method	Manual/Electric witch/Hydraulic	Manual/Electric witch/Hydraulic
Light Rotation	No/355 degrees optional	No/355 degrees optional
Light Angle Adjust	Electric actuator	Electric actuator
<b>Trailer</b>		
Suspension	Leaf spring with mechanical braker	Leaf spring with mechanical braker
Towing Bar	A frame with Jockey wheel	Foldable Tow bar with Jockey wheel
Stabilizing Leg	4Pcs Manual Stabilizing Leg	4Pcs Manual Stabilizing Leg
Rim & Tyre	14"	14"
Towing coupler	50mm ball / 70mm Ring	50mm ball / 70mm Ring
Tail Lights	complex tail light	complex tail light
Max Towing speed	80km/h	80km/h
<b>Other Item</b>		
Fuel Tank Type	Metal	Metal
Fuel Tank capacity	45L	45L
Operating hours	30 Hrs	30 Hrs
Controller	UK DEEPSEA DSE4520	UK DEEPSEA DSE4520
Output	2 receptacles	2 receptacles
Max.Against Wind	20 m/s	20 m/s
Noise level dBA@7M	63dB(A) at 7m	63dB(A) at 7m
Max.Loading Qty by 40HQ	14	14

The above parameters are for reference only. All products are subject to the actual products received.

# HiDIESEL

## Diesel Light Tower



MODEL	BLGT-4000LMH	BLGT-4000LLED
<b>Unit</b>		
Genset rated Power (KW)	6	6
Dimension	3031×1488×3327mm	3031×1488×3220mm
Height extended fully	7.5m (9m optional)	7.5m (9m optional)
Gross Weight	1300kgs	1300kgs
<b>Engine</b>		
Engine Model	Laidong KM385BD	Laidong KM385BD
Rated Speed (rpm)	1500/1800	1500/1800
Cylinder No.	3	3
Engine type	4 stroke,water-cooled	4 stroke,water-cooled
Air intake method	Naturally aspirated	Naturally aspirated
Emission	Non-emission	Non-emission
<b>Alternator</b>		
Model	kWISE KAL164A1	kWISE KAL164A1
Frequency (HZ)	50/60	50/60
Rated voltage	230V (50HZ), 240(60HZ) AC	230V (50HZ), 240(60HZ) AC
Insulation class	Class H	Class H
Protection grade	IP23	IP23
<b>Mast and Light</b>		
Light type	Metal Halide	LED
Luminous Flux	360000 LM	210000 LM
Light Qty x WATT	4×1000W	4×350W
Mast Sections	5	5
Mast lifting method	Manual/Electric witch/Hydraulic	Manual/Electric witch/Hydraulic
Mast Rotation	No/355 degrees optional	No/355 degrees optional
Light Angle Adjust	Electric actuator	Electric actuator
<b>Trailer</b>		
Suspension	Leaf spring with mechanical braker	Leaf spring with mechanical braker
Towing Bar	A frame with Jockey wheel	Foldable Tow bar with Jockey wheel
Stabilizing Leg	4Pcs Manual Stabilizing Leg	4Pcs Manual Stabilizing Leg
Rim & Tyre	14"	14"
Towing coupler	50mm ball / 70mm Ring	50mm ball / 70mm Ring
Tail Lights	complex tail light	complex tail light
Max Towing speed	80km/h	80km/h
<b>Other Item</b>		
Fuel Tank Type	Metal	Metal
Fuel Tank capacity	45L	45L
Operating hours	30 Hrs	30 Hrs
Controller	UK DEEPSEA DSE4520	UK DEEPSEA DSE4520
Output	2 receptacles	
Max.Against Wind	20 m/s (45mph)	20 m/s (45mph)
Noise level dBA@7M	63dB(A) at 7m	63dB(A) at 7m
Max.Loading Qty by 40HQ	14	14

The above parameters are for reference only. All products are subject to the actual products received.

# HiDIESEL

## Diesel Light Tower



MODEL	BLGT-10QL
<b>Unit</b>	
Genset rated Power (KW)	7
Dimension	3750×1700×2500mm
Height extended fully	8.5m
Gross Weight	1920kgs
<b>Engine</b>	
Engine Model	Perkins 403D-11G
Rated Speed (rpm)	1500/1800
Cylinder No.	3
Engine type	4 stroke,water-cooled
Air intake method	Naturally aspirated
Emission	Tier3
<b>Alternator</b>	
Model	MeccAlte LT3N-160/4
Frequency (HZ)	50/60
Rated voltage	230V (50HZ), 240(60HZ) AC
Insulation class	Class H
Protection grade	IP23
<b>Mast and Light</b>	
Light type	LED
Luminous Flux	360000 LM
Light Qty x WATT	8×300W
Mast Type	Hydraulic excavator type
Mast lifting method	Hydraulic
Light Rotation	Electric motor 355 degrees
Light Angle Adjust	Electric actuator
<b>Trailer</b>	
Suspension	Leaf spring with mechanical braker
Towing Bar	Foldable Tow bar with Jockey wheel
Stabilizing Leg	4Pcs Hydraulic Stabilizing Leg
Rim & Tyre	15"
Towing coupler	50mm ball / 70mm Ring
Tail Lights	complex tail light
Max Towing speed	80km/h
<b>Other Item</b>	
Fuel Tank Type	Metal
Fuel Tank capacity	300L
Operating hours	240 Hrs
Controller	Smartgen ALC708
Output	2 receptacles
Max.Against Wind	20 m/s
Noise level dBA@7M	63dB(A) at 7m
Max.Loading Qty by 40HQ	5

The above parameters are for reference only. All products are subject to the actual products received.

# HiDIESEL

## Diesel Light Tower



MODEL	BLGT-1600	BLGD-Q5A-4R
<b>Unit</b>		
Genset rated Power (KW)	4.5	4.5
Dimension	1200×600×1850mm	2378×1200×2850mm
Height extended fully	9m	4.5m
Gross Weight	385kgs	610kgs
<b>Engine</b>		
Engine Model	UN186FA	UN186FA
Rated Speed (rpm)	3000/3600	3000/3600
Cylinder No.	1	1
Engine type	4 stroke,air-cooled	4 stroke,air-cooled
Air intake method	Naturally aspirated	Naturally aspirated
Emission	Non-emission	Non-emission
<b>Alternator</b>		
Model	UN4.5	UN4.5
Frequency (HZ)	50/60	50/60
Rated voltage	220/110V (50HZ), 240/120 (60HZ) AC	220/110V (50HZ), 240/120 (60HZ) AC
Insulation class	Class H	Class H
Protection grade	IP23	IP23
<b>Mast and Light</b>		
Light type	Metal Halide	LED
Luminous Flux	160000 LM	180000 LM
Light Qty x WATT	4×400W	4×300W
Mast Sections	4	4
Mast lifting method	Manual	Manual
Mast Rotation	/	/
Light Angle Adjust	Manual	Manual
<b>Trailer</b>		
Suspension	/	Leaf spring without braker
Towing Bar	/	Foldable Tow bar with Jockey wheel
Stabilizing Leg	4Pcs Manual Stabilizing Leg	4Pcs Manual Stabilizing Leg
Rim & Tyre	12"	14"
Towing coupler	/	50mm ball / 70mm Ring
Tail Lights	Reflector	Reflector
Max Towing speed	80km/h	80km/h
<b>Other Item</b>		
Fuel Tank Type	Metal	Metal
Fuel Tank capacity	15L	15L
Operating hours	10 Hrs	10 Hrs
Control panel	Key start	Key start
Output	2 receptacles	2 receptacles
Max.Against Wind	20 m/s	20 m/s
Noise level dBA@7M	65dB(A) at 7m	65dB(A) at 7m
Max.Loading Qty by 40HQ	36	18

The above parameters are for reference only. All products are subject to the actual products received.



**YOUR POWER OUR PASSION**



**BIGLUX INNOVATION LTD**

[www.bigluxsolar.com](http://www.bigluxsolar.com)    [www.bigluxled.com](http://www.bigluxled.com)

**WhatsApp:** +86 188 1878 5601  
**Email:** [info@bigluxsolar.com](mailto:info@bigluxsolar.com)

**Address:** #1002 West Tower, LaoBing Building, No. 3012 XingYe Rd, BaoAn, ShenZhen, China